



DRAGONET SPORT TECHNOLOGY
COMPANY PROFILE



INDEX

- 3. History and Background
- 4. Mission and Vision
- 6. Products
- 9. Technological Innovations
- 12. Strategic Objectives
- 15. Customers and Partnerships
- 18. Team and Skills
- 21. Research and Development
- 23. Financial Data



DRAGONET

INTRODUCTION

Dragonet Sport Technology emerges from the vision of revolutionizing racket sports training, merging innovation and passion to create cutting-edge solutions that make training more accessible and enjoyable for everyone.

Our commitment is reflected in innovative products that radically transform the training experience, making sports practice possible anytime, anywhere, without limits.



HISTORY & BACKGROUND

Dragonet Sport Technology took shape in 2017 when Giuseppe Spedalieri's passion for tennis merged with his son Alessandro's electronics and programming skills. This winning combination gave birth to Dragonet, a machine designed to revolutionize training in racket sports, surpassing the limits of traditional ball machines.

Our creation, Dragonet, is not just a product; it is a one-of-a-kind innovation. Our system is in fact recognized and patented in various international markets, including Europe, Canada and the United States, confirming its uniqueness in the panorama of sports training tools.

Today, Dragonet is a global presence, spreading to over 30 countries through collaboration with numerous distributors. This success is anchored in our vision to make training in racket sports more accessible and exciting.

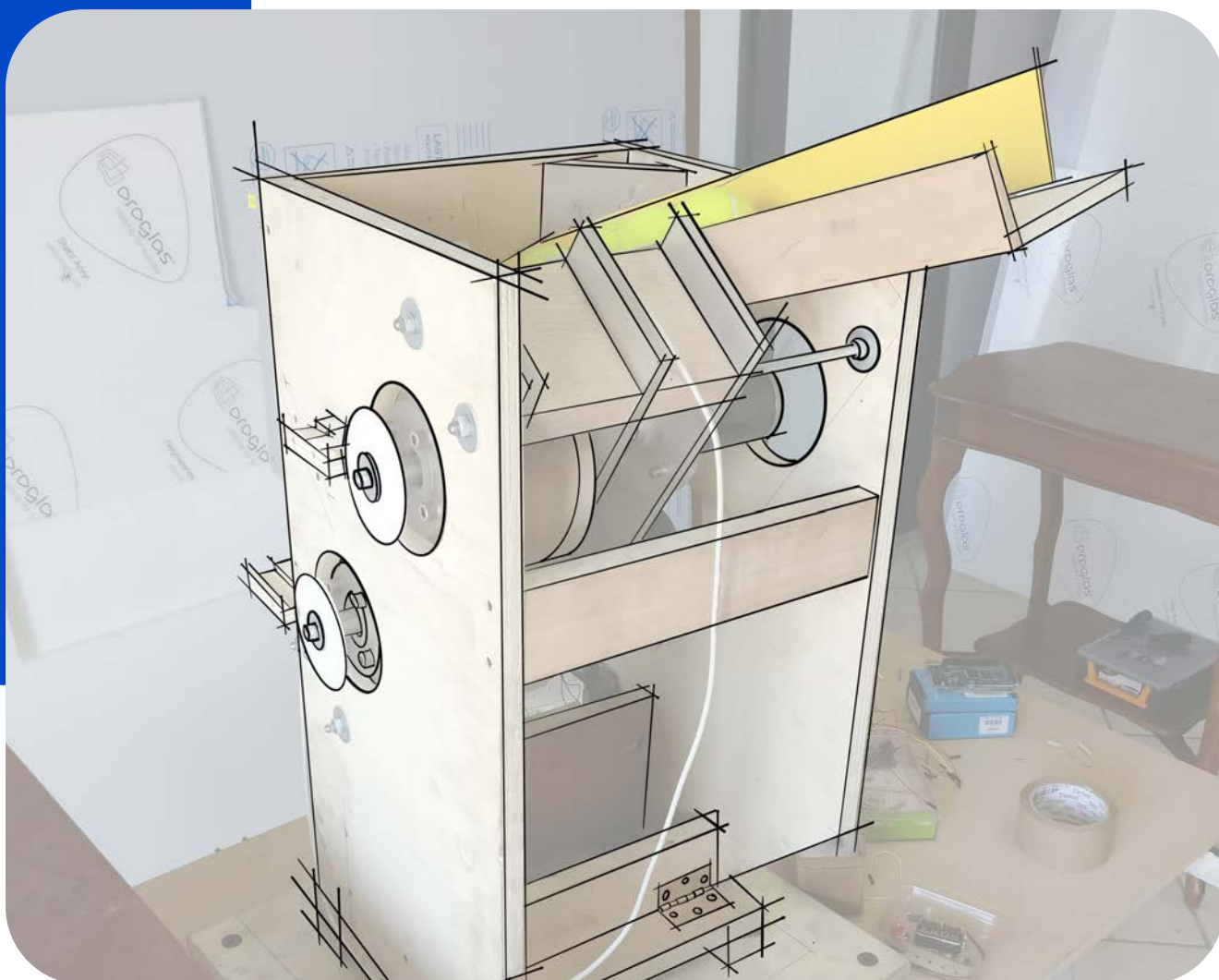



MISSION

We commit to redefine racket sports training in an innovative way.

We aim to offer technologically advanced solutions that not only enhance athletes' performance but also create a new approach in the field.

We are here to inspire and challenge, providing engaging and personalized training experiences, breaking down barriers, and making access to the best available technologies for everyone.



VISION

We look to the future with enthusiasm, being at the forefront of shaping the evolution of racket sports through technology.

Our vision is a landscape where Dragonet becomes an intelligent companion, capable of anticipating and adapting to athletes' needs. We dream of a world where the synergy between human and technology is not just a reality but the key to overcoming limits and creating extraordinary performances.

Our constant pursuit of innovation is inspired by a passion for technological advancement, driving us to be pioneers in the digital transformation of racket sports.

PRODUCTS





PRODUCTS

PRO

With Dragonet Pro, we present you the best of technology for padel and tennis training.

Each session is customizable through the touchscreen display setting the number and type of shots, spin, playing distance, and feed ratio. Pro's automated multidirectional launch system allows to alternate all shots, both horizontally and vertically.

By adjusting the bouncing plate's inclination, it's possible simulate lobs up to 6m, thus also training smashes.



PRODUCTS

STARTER

Starter features all of Dragonet's functionalities in an even smaller space: its compact structure of only 2.5m makes it perfect for any garage or sports store.

Shot settings are controlled through three knobs with 10 levels of adjustment. It is possible to set spin, playing distance, and feed ratio.

With Starter's single-directional launch system, you can also work on your athletic preparation: to alternate forehand and backhand shots, it'll be important focus on footwork and shot preparation speed.



TECHNOLOGICAL INNOVATIONS





TECHNOLOGICAL INNOVATIONS

Dragonet Sport Technology is at the forefront of technological innovation, redefining the concept of training in racket sports through unique and advanced solutions. Our machines integrate cutting-edge technologies to offer an unprecedented training experience.

Patented Continuous Cycle System:

Our patented system works only with five balls and eliminates the need to collect them at the end of the session, allowing continuous and uninterrupted training.

Innovative Versatility in Use:

Thanks to the integrated adjustable plate, Dragonet optimizes ball bounce, opening up the possibility to train on any surface, from grass to sand, in unconventional spaces like terraces or garages.

Top-tier Customization:

Our machines allow you to choose from a wide range of settings. Parameters such as number of shots, distance, frequency, direction, and spin can be personalized for a realistic simulation of every game situation.



TECHNOLOGICAL INNOVATIONS

SMART TARGET

Additionally, by the end of 2024, we will launch our brand-new Smart Targets - a revolutionary innovation in performance monitoring.

These smart targets, in direct communication with Dragonet Pro, detect the shot at impact. This intelligent connection enables automatic scorekeeping at the end of each training session, making the precision and competition experience more engaging than ever.

During events, they become an extraordinary entertainment element, challenging players to improve their accuracy and creating engaging and fun competitions among participants.

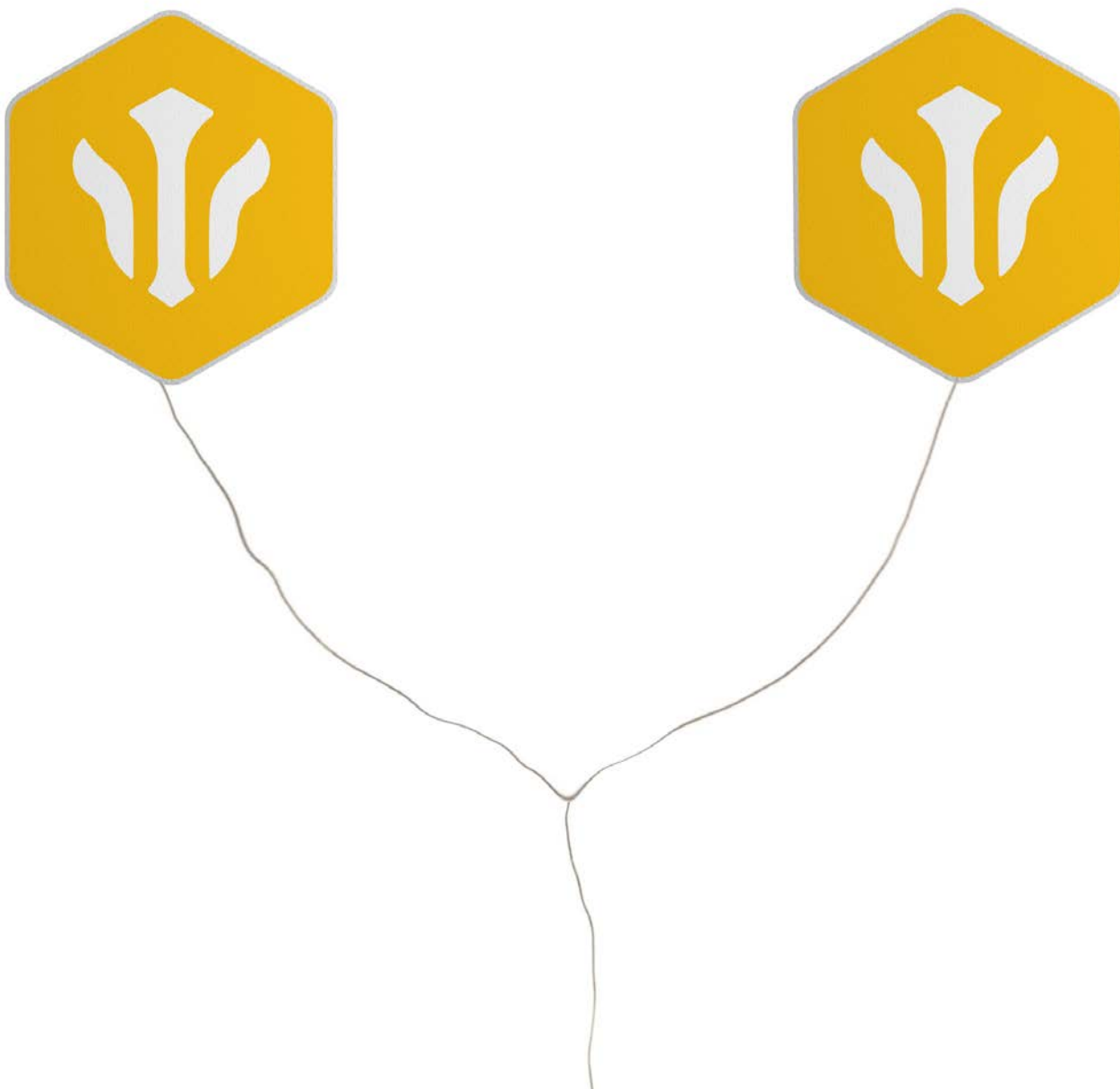

STRATEGIC OBJECTIVES





OBJECTIVES

SHORT TERM



Market Expansion:

Focus on market penetration, identifying and establishing strategic partnerships with key distributors in regions where Dragonet is still underrepresented.

Technological Upgrades:

Regularly implement technological updates for Dragonet machines, ensuring they are cutting-edge and meet the growing needs of users.

Launch of Dragonet Pickleball:

Introduce to the market a machine specifically designed for pickleball, thus expanding the range of Dragonet products and responding to the demands of a growing base of enthusiasts of this growing sport.



OBJECTIVES

LONG TERM

Creation of New Warehouses:

Establish warehouses in strategic locations worldwide, optimizing production and shipping processes to reduce delivery times and improve operational efficiency.

Global Brand Consolidation:

Position Dragonet as the undisputed leader in the industry, increasing global presence through targeted marketing campaigns, participation in international events, and consolidation of strategic alliances.

Expansion of Product Line:

Continue to innovate and diversify the range of Dragonet products, introducing new features and models to cover a wide variety of user needs and preferences.

Development of Technological Partnerships:

Collaborate with leading companies to integrate the latest technologies into Dragonet machine design, ensuring a leading position in the sports training ecosystem.

Investments in Research and Development:

Increase investments in research and development to anticipate industry trends and maintain leadership in sports training innovation.

Already from 2019, Dragonet's international appeal has consistently garnered significant traction. Today, we have machines working across a diverse landscape spanning over 30 countries, demonstrating the widespread adoption and global presence of our technology.



CLIENTS & PARTNERSHIP

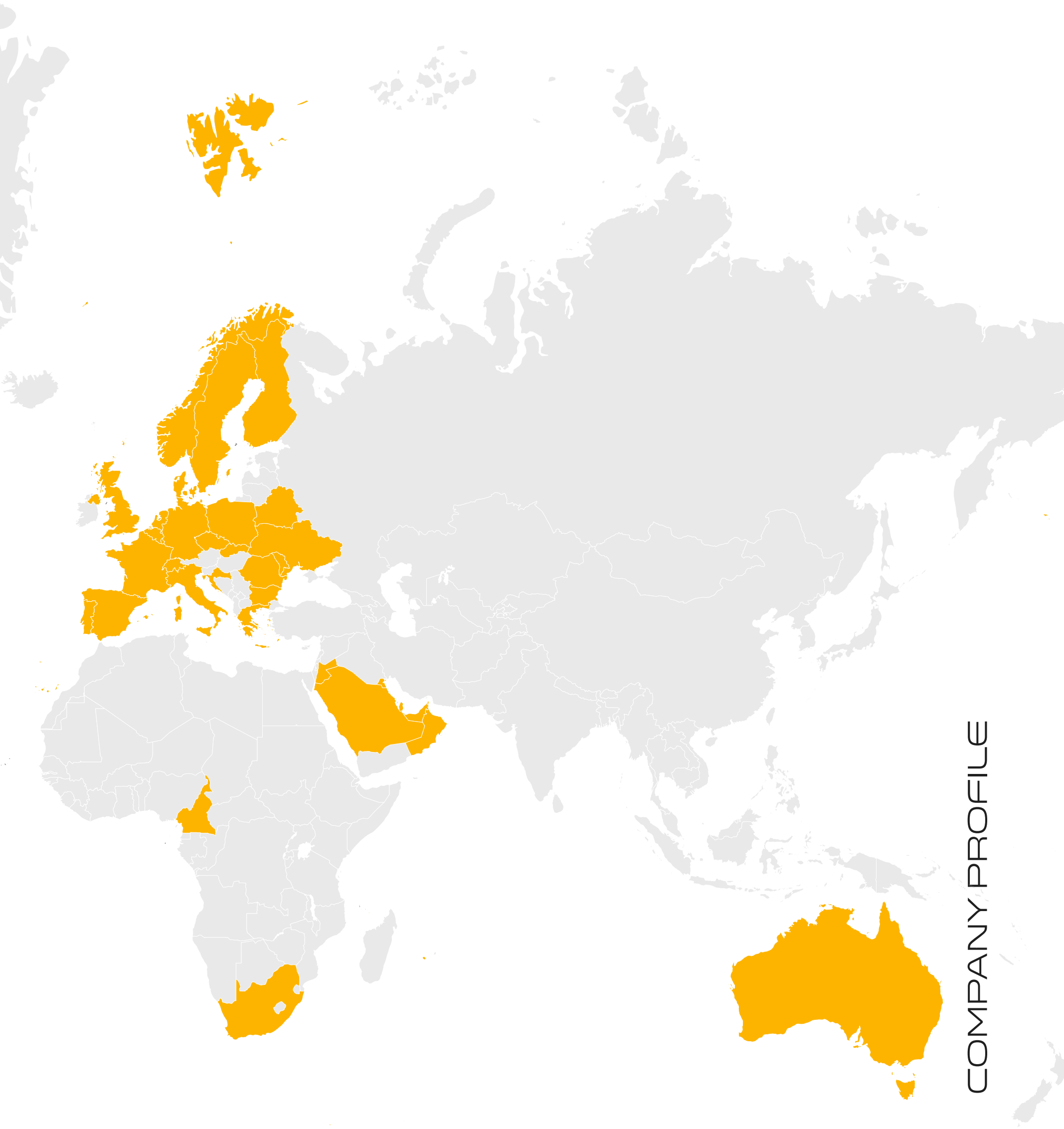

COMPANY PROFILE



CLIENTS & PARTNERSHIP



TEAM AND SKILLS





TEAM AND SKILLS

Giuseppe Spedaliere – Production Manager & Co-Founder:

Thirty years of experience in the construction and manufacturing industry. Visionary in conceiving and implementing innovative solutions for sports training.

Alessandro Spedaliere – CEO & Co-Founder:

Advanced skills in electronics and programming. Strategic guidance and clear vision of Dragonet's positioning in the global market.

Marco Staiano – Sales & Shipping Manager:

Advanced skills in sales and logistics management. Experience in creating efficient distribution networks to ensure global coverage.

Giovanni Portoghese – Marketing & Media Manager:

Expert in defining and implementing marketing strategies. Creative in devising engaging content, contributing to building a strong bond between Dragonet and its global community.

Anna De Lauzieres – Accounting Manager:

Specialization in financial management and accounting. Experience in ensuring a solid financial structure to support business growth.



TEAM AND SKILLS

The leadership team at Dragonet Sport Technology features a unique blend of skills and experiences contributing to the company's ongoing success.

Deep industry knowledge, combined with advanced technical skills, allows the team to lead Dragonet toward constant innovation and sustainable growth. We have chosen to manufacture our machines in Italy and to maintain the highest possible quality at every stage of production, creating a workshop and a tailor's to take care of every detail meticulously

Effective management of operations, from production to distribution, is crucial to ensuring the quality and availability of Dragonet products worldwide. Furthermore, marketing and communication skills enable us to position Dragonet as a future market leader and to connect meaningfully with the global racket sports enthusiast community.

The diversity of skills within the team is one of the keys to Dragonet's success, leading to an integrated.





RESEARCH AND DEVELOPMENT APPROACH

Dragonet Sport Technology is committed to fostering innovation through substantial investment in Research and Development (R&D). This commitment results in the relentless improvement of the performance of our machines and the introduction of new advanced features.

Anticipating Trends

We invest in proactive research to understand and anticipate emerging trends in the world of racquet sports, enabling us to introduce innovative solutions and adapt to changing market needs

Strategic Collaborations:

We enter into partnerships with research institutes, universities, and industry experts to leverage specialized knowledge and foster a culture of open innovation, providing us with key insights and valuable resources.

Continuous Technology Development:

We devote resources to developing cutting-edge technologies to constantly improve the performance of our machines, ensuring that they live up to the expectations of athletes and enthusiasts.



RESEARCH AND DEVELOPMENT BENEFITS

Cutting-Edge Products:

Our investment in R&D enables us to offer cutting-edge Dragonet products with innovative features and superior performance compared to the competition.

Global Competitiveness:

By maintaining a focus on R&D, we strengthen our global leadership in the racquet sports industry, attracting the attention of athletes and enthusiasts worldwide.

Long-Term Sustainability:

Our dedication to R&D reflects our commitment to long-term sustainability, keeping our products in step with the evolving racquet sports landscape over time.



FINANCIAL DATA

Percentage Growth:

Dragonet Sport Technology has shown robust year-over-year growth. The revenue growth percentage for the last fiscal year was 48% compared to the previous year, demonstrating the effectiveness of the company's marketing strategies and the increasing confidence of customers in its products.

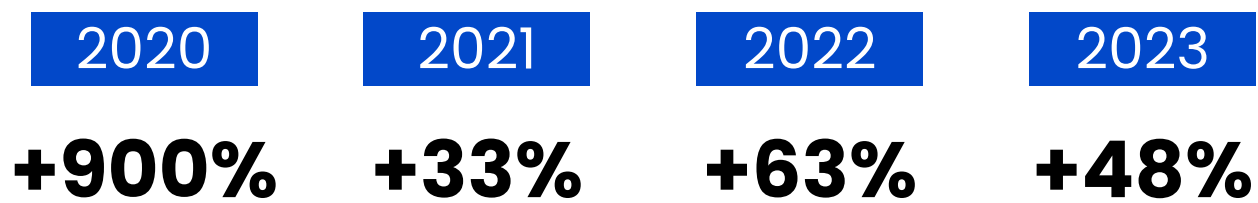

Investments in Research and Development:

Dragonet Sport Technology's commitment to innovation is reflected in its investments in research and development, which have totaled €350,000 over the past 6 years.

from 2017 to 2023

+350.000€

Financial Indebtedness:

Dragonet Sport Technology stands out for its solid financial position, having achieved zero financial indebtedness. This condition demonstrates the excellent management of financial resources by the company and provides a stable foundation for future expansion and product development.



DRAGONET SPORT TECHNOLOGY

INFO@DRAGONET.IT

WWW.DRAGONET.IT

[@DRAGONET.OFFICIAL](#)

